



22

Vol.76

21

13



TEL : 03-5253-1111 ( 3944)  
FAX : 03-3503-7894

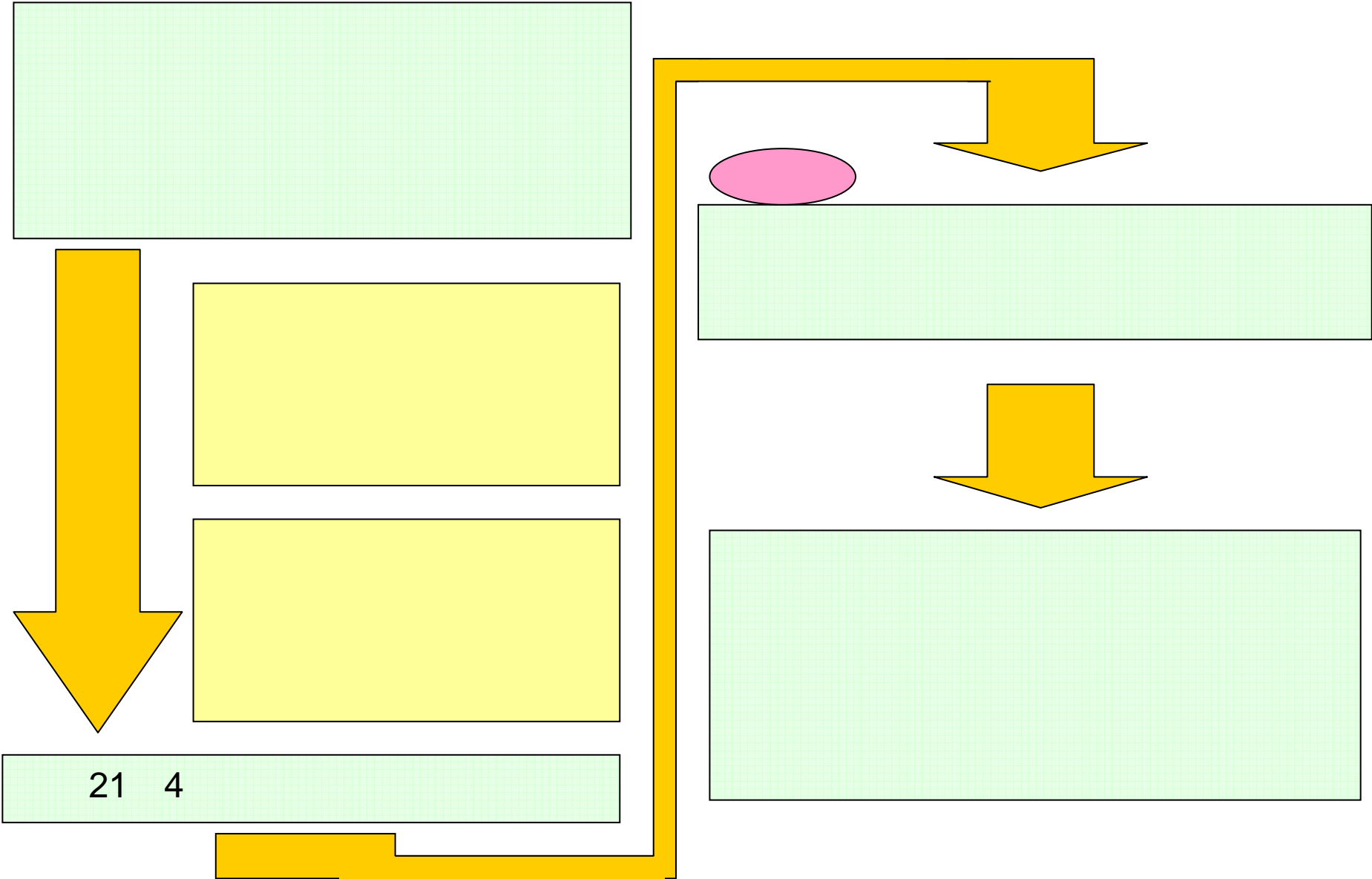
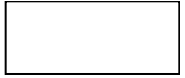

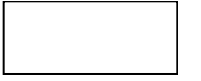

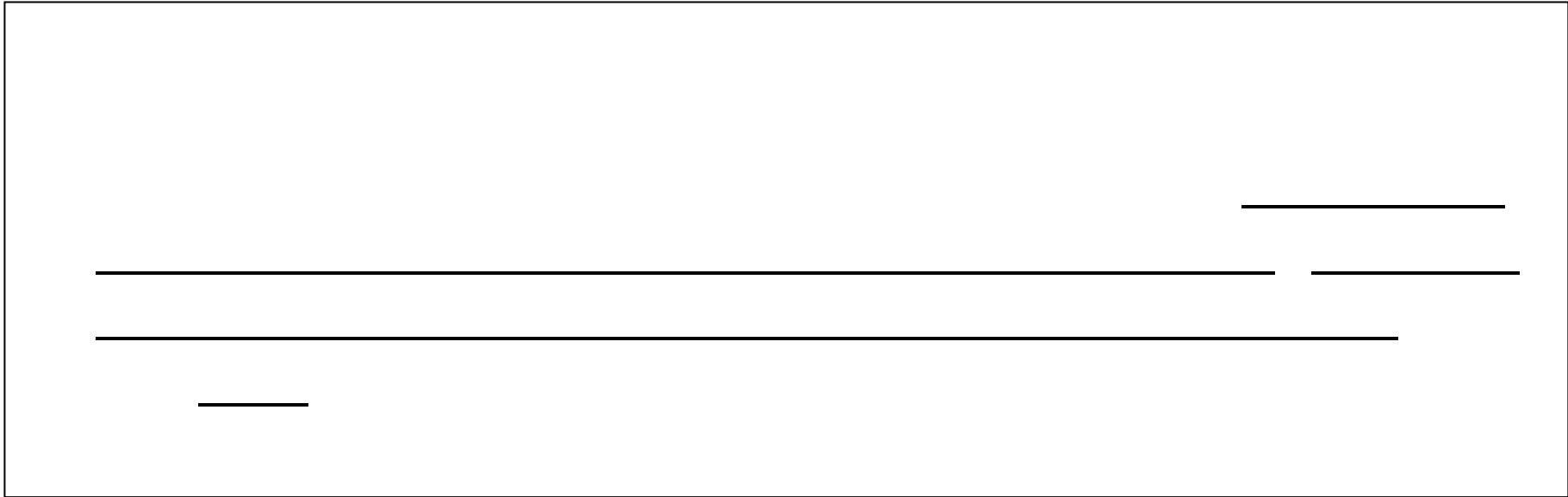
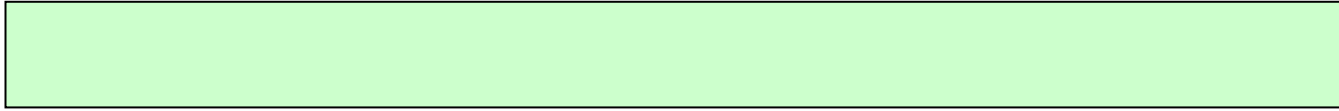

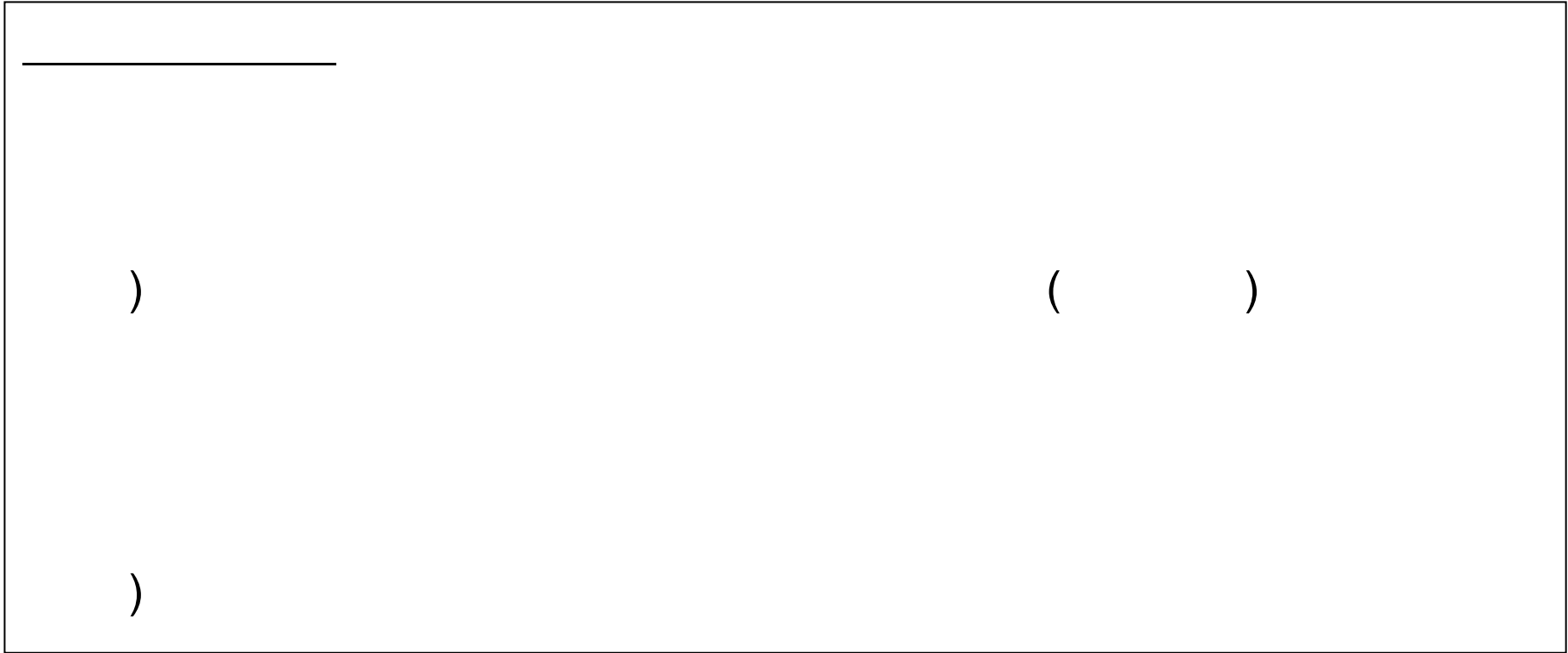

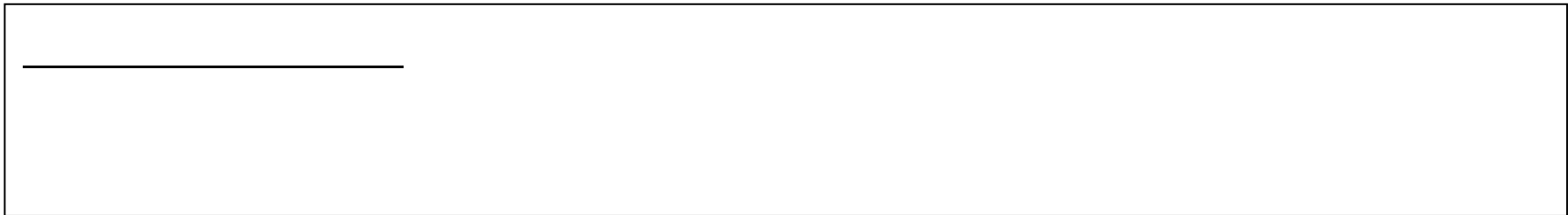
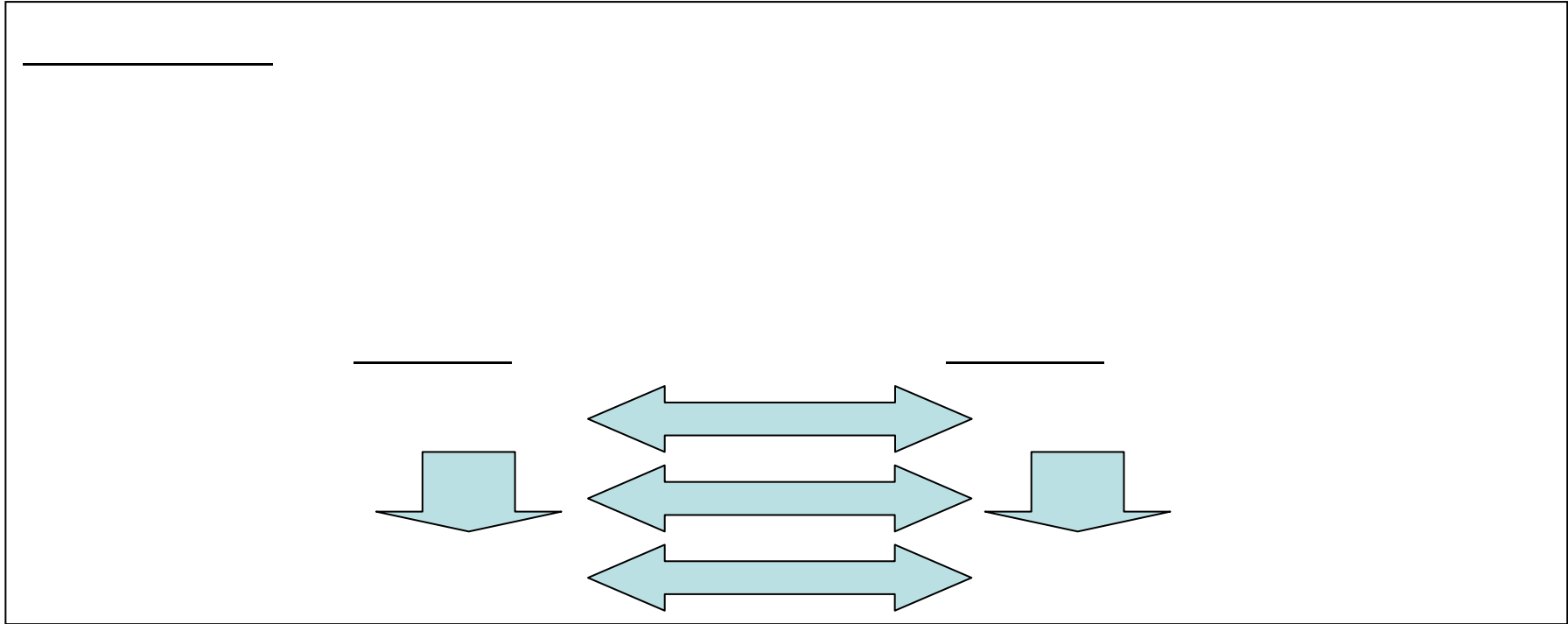

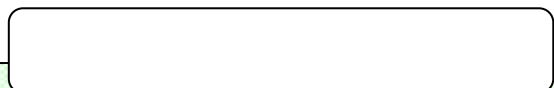
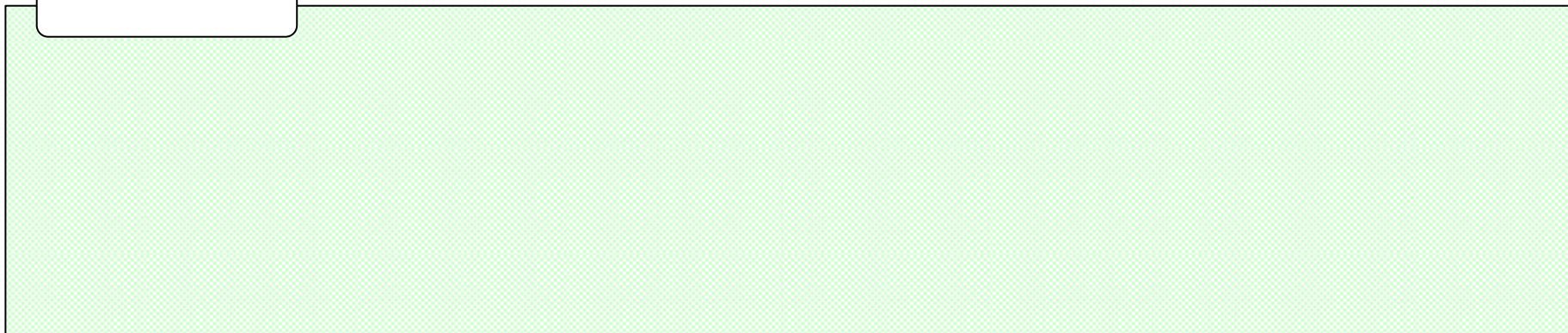

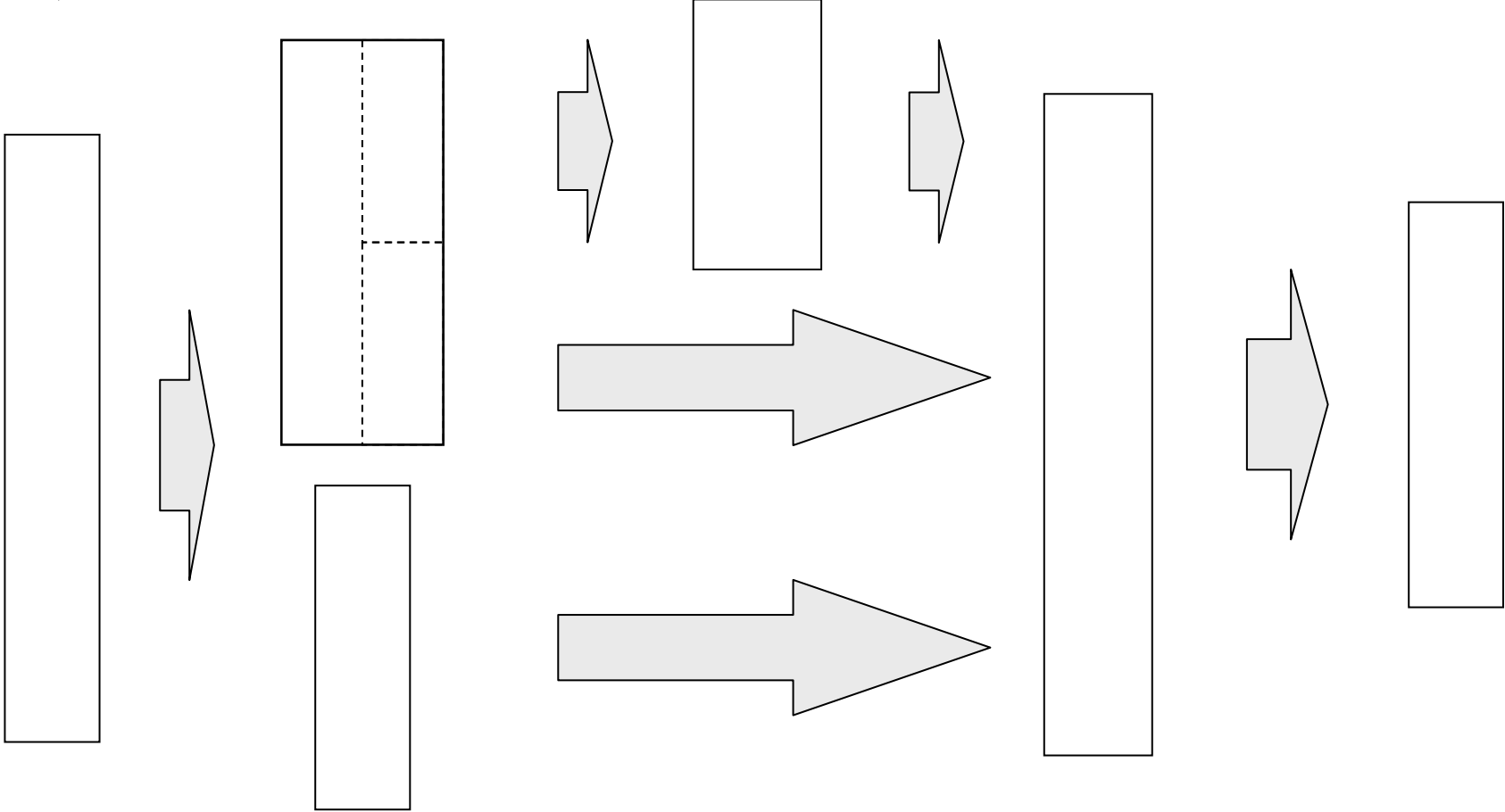
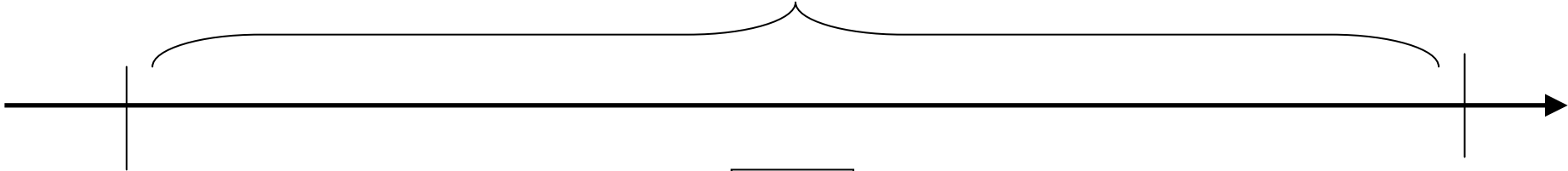
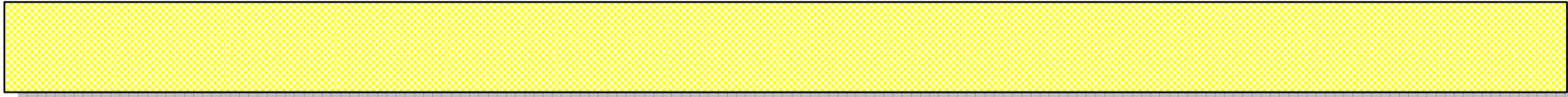





# 目次

( )

10

4

11

\_\_\_\_\_

\_\_\_\_\_

\_\_\_\_\_

\_\_\_\_\_

\_\_\_\_\_

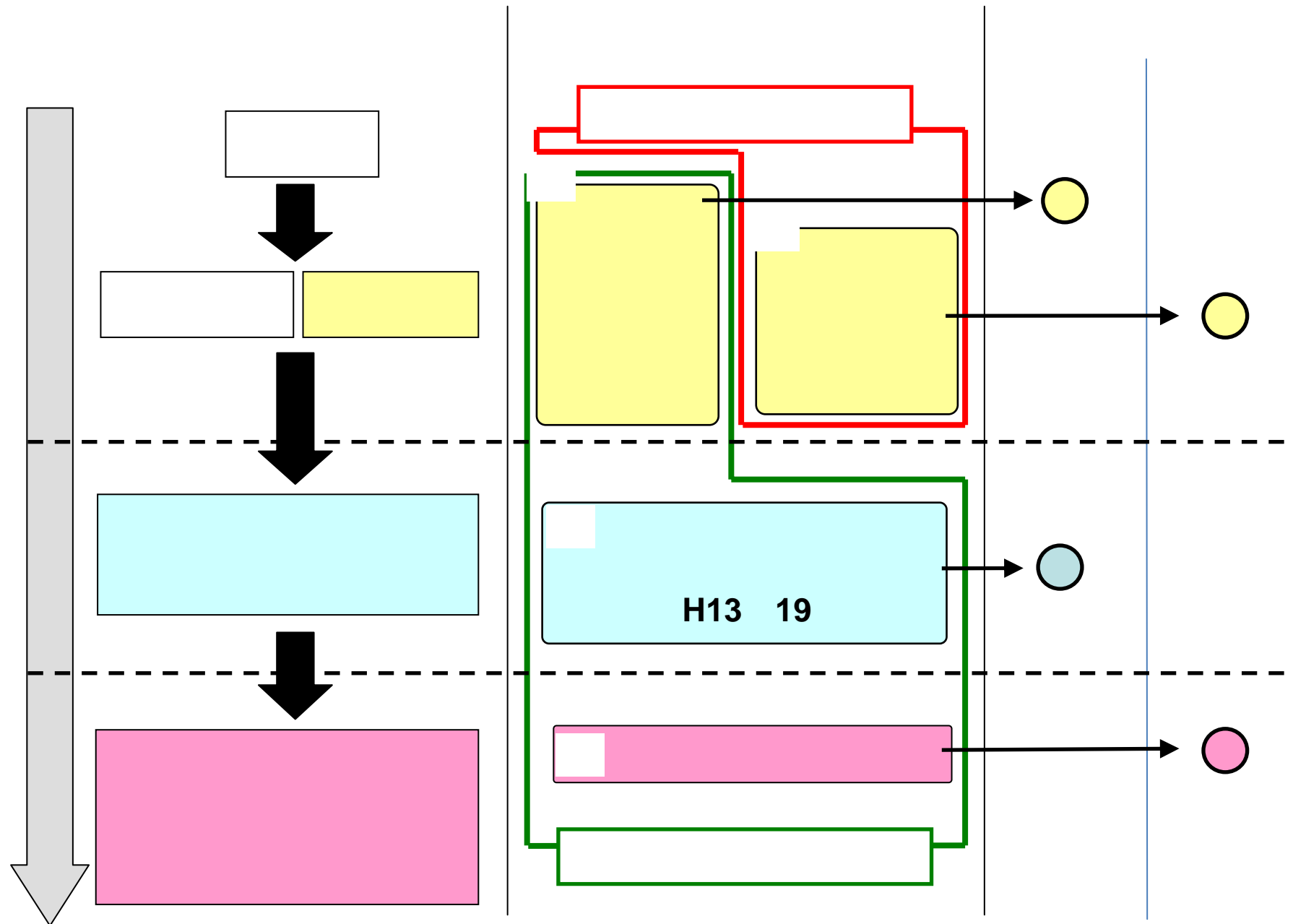

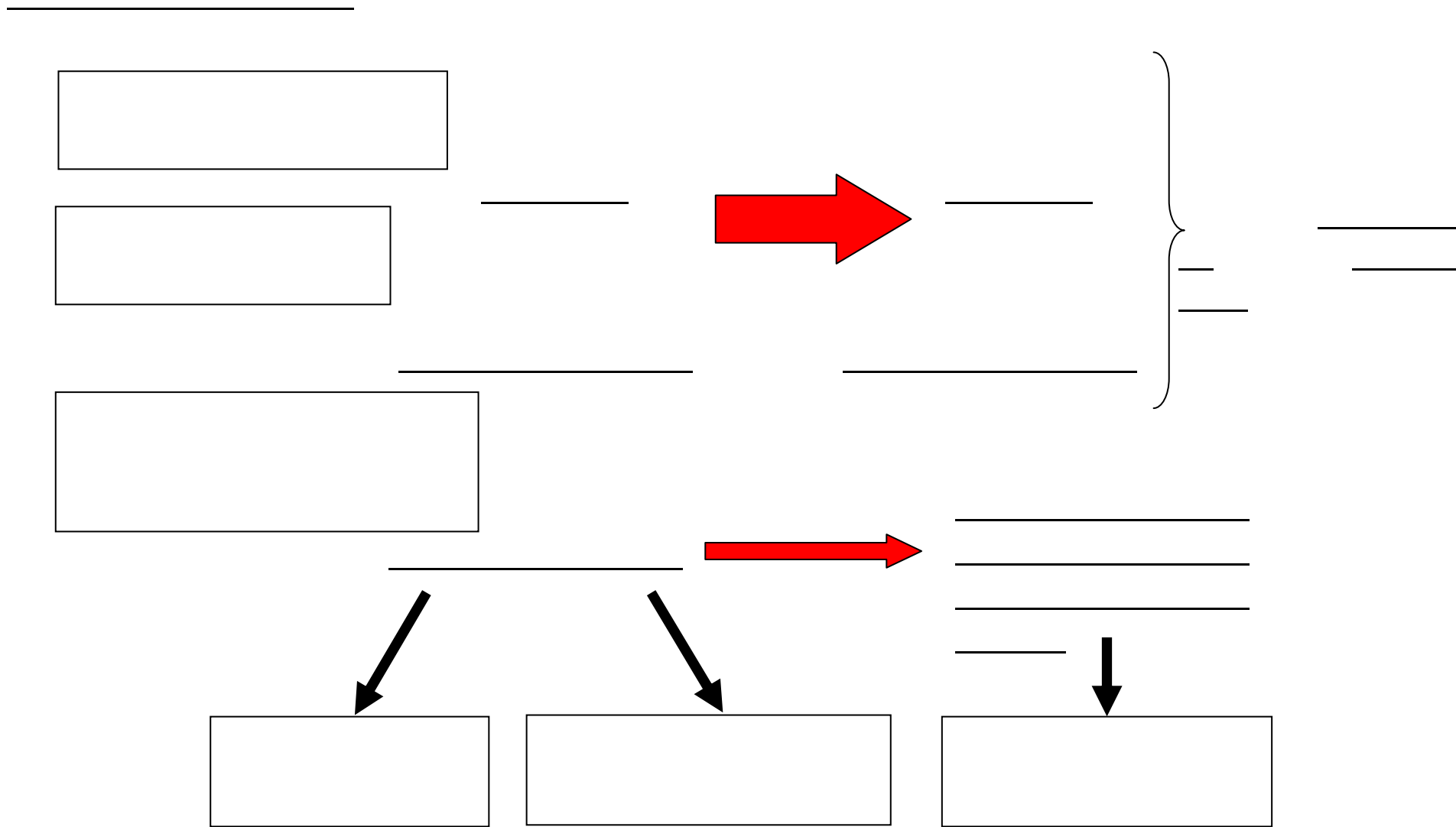

一次判定結果 : 要介護4

要介護認定等基準時間 : 106.1分

1 一次判定等

一次判定結果 : 要介護2

要介護認定等基準時間 : 57.1分

食事	排泄	移動	清潔保持	間接	間接行動	機能訓練	医療関連
0.7分	21.3分	2.7分	16.5分	3.6分	0.4分	1.5分	10.4分

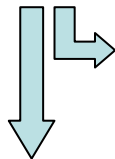
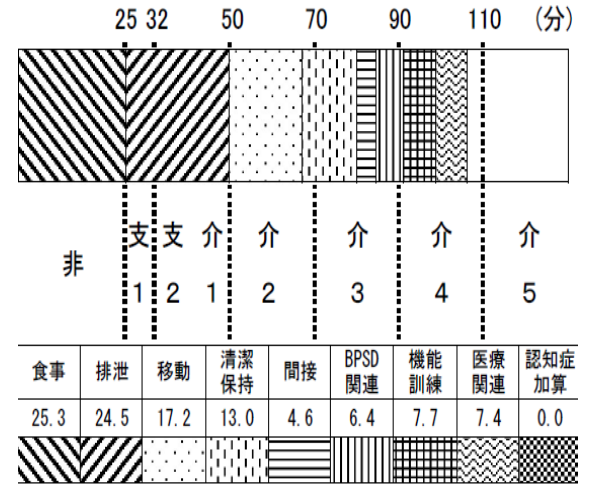

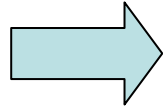

- 「独り言・独り笑い」
- 「自分勝手に行動する」
- 「話がまとまらない」
- 「集団への不応」
- 「買い物」
- 「簡単な調理」

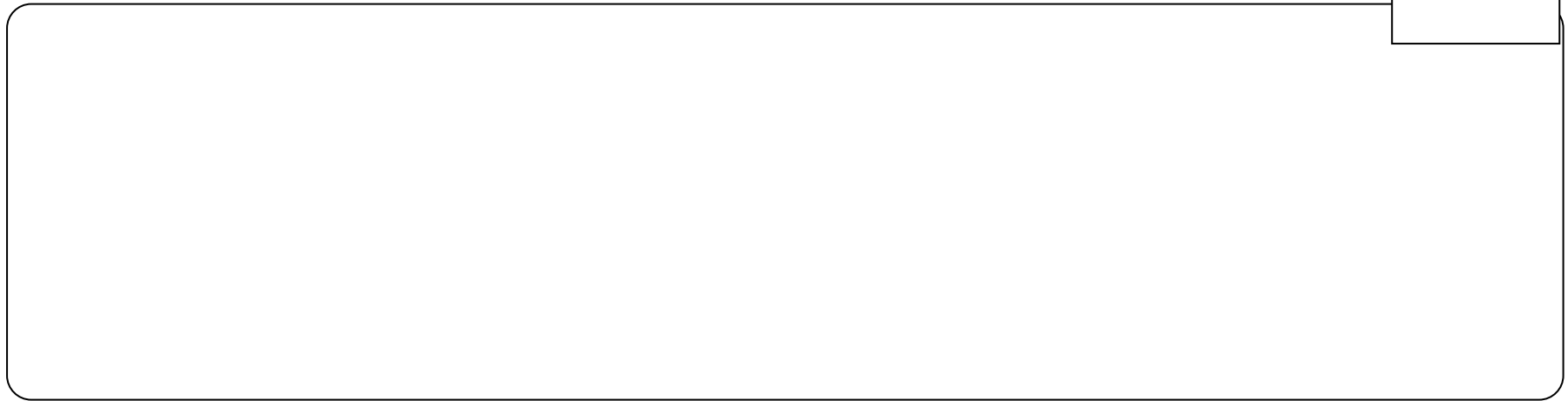
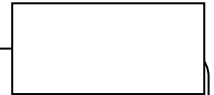
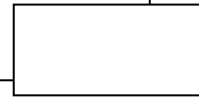

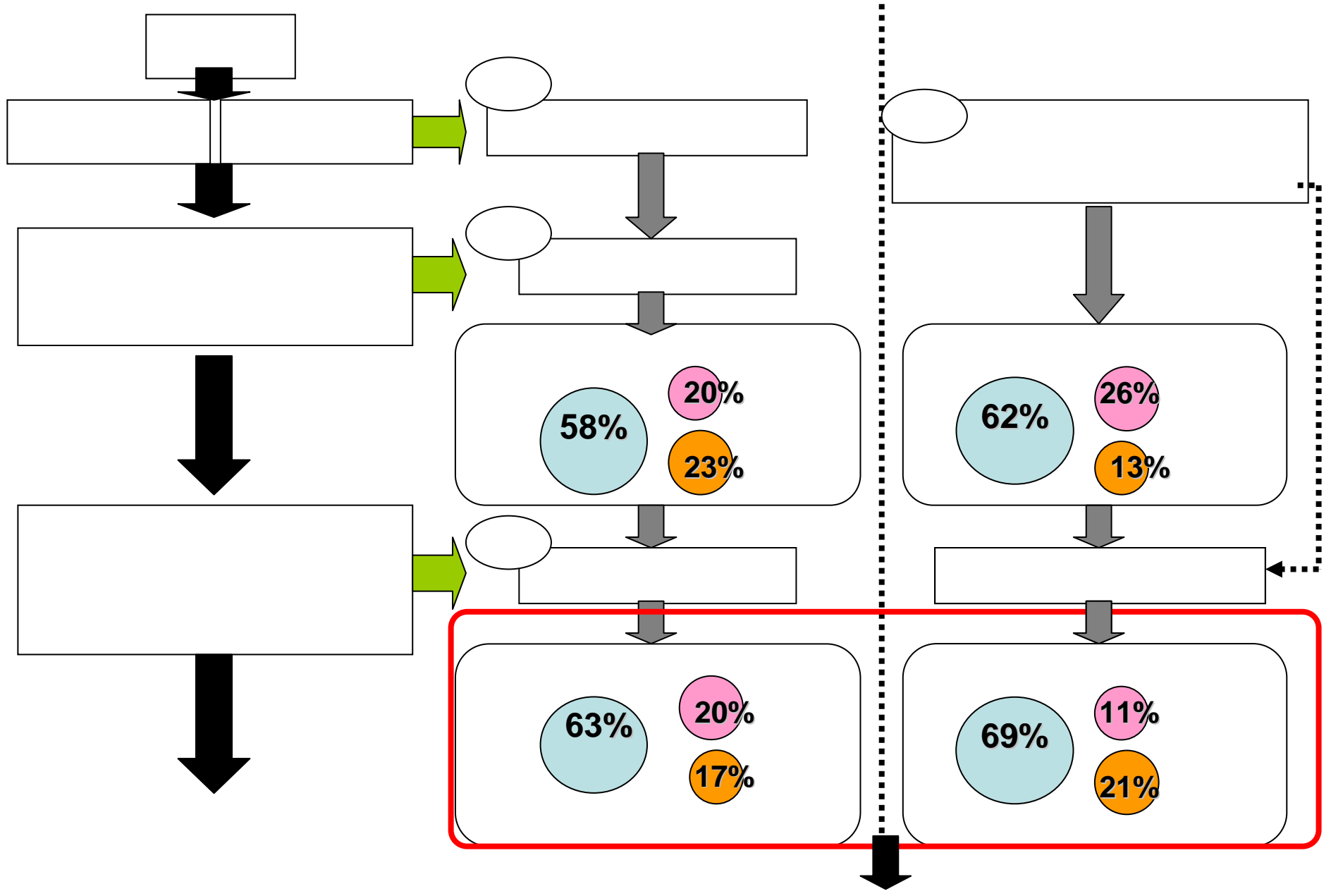



( )

	1.5%	19.4%	20.6%	19.5%	14.4%	11.5%	7.3%	6.0%
	1.7%	21.7%	17.2%	21.0%	14.3%	10.5%	7.9%	5.7%

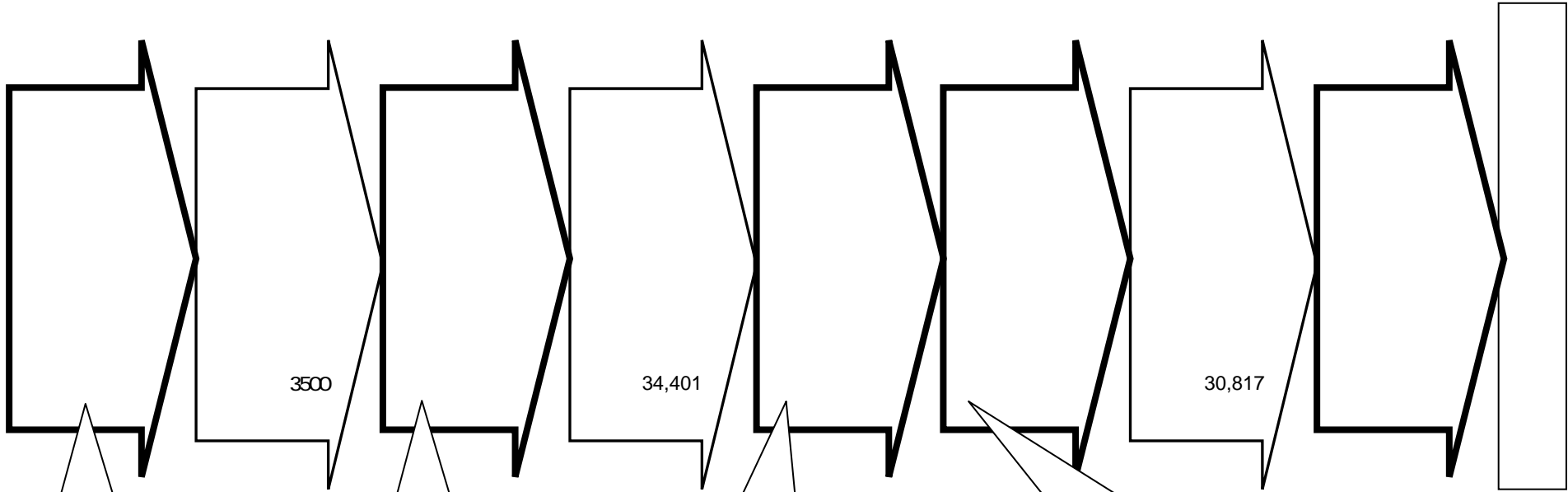

\_\_\_\_\_

\_\_\_\_\_

\_\_\_\_\_

\_\_\_\_\_

\_\_\_\_\_

\_\_\_\_\_

\_\_\_\_\_

\_\_\_\_\_

\_\_\_\_\_

\_\_\_\_\_

\_\_\_\_\_

\_\_\_\_\_

\_\_\_\_\_

\_\_\_\_\_

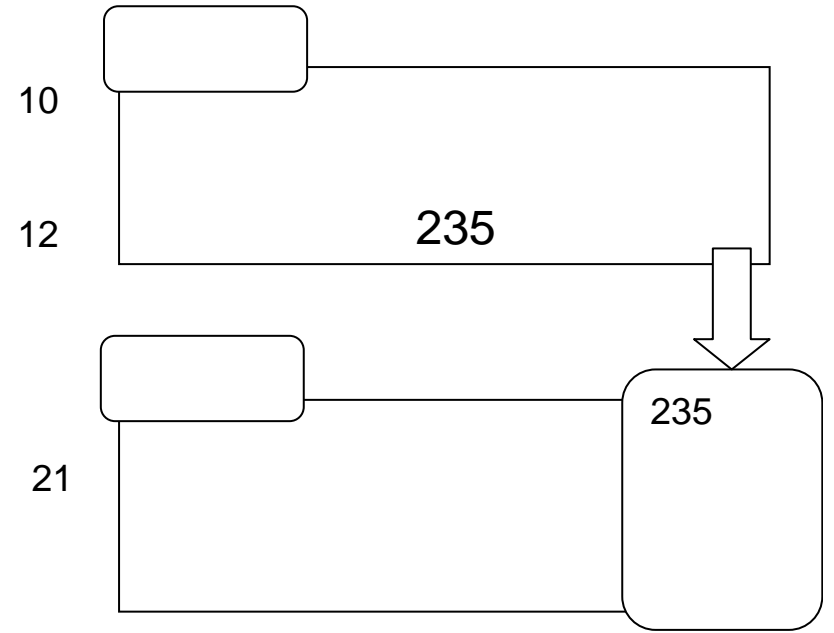
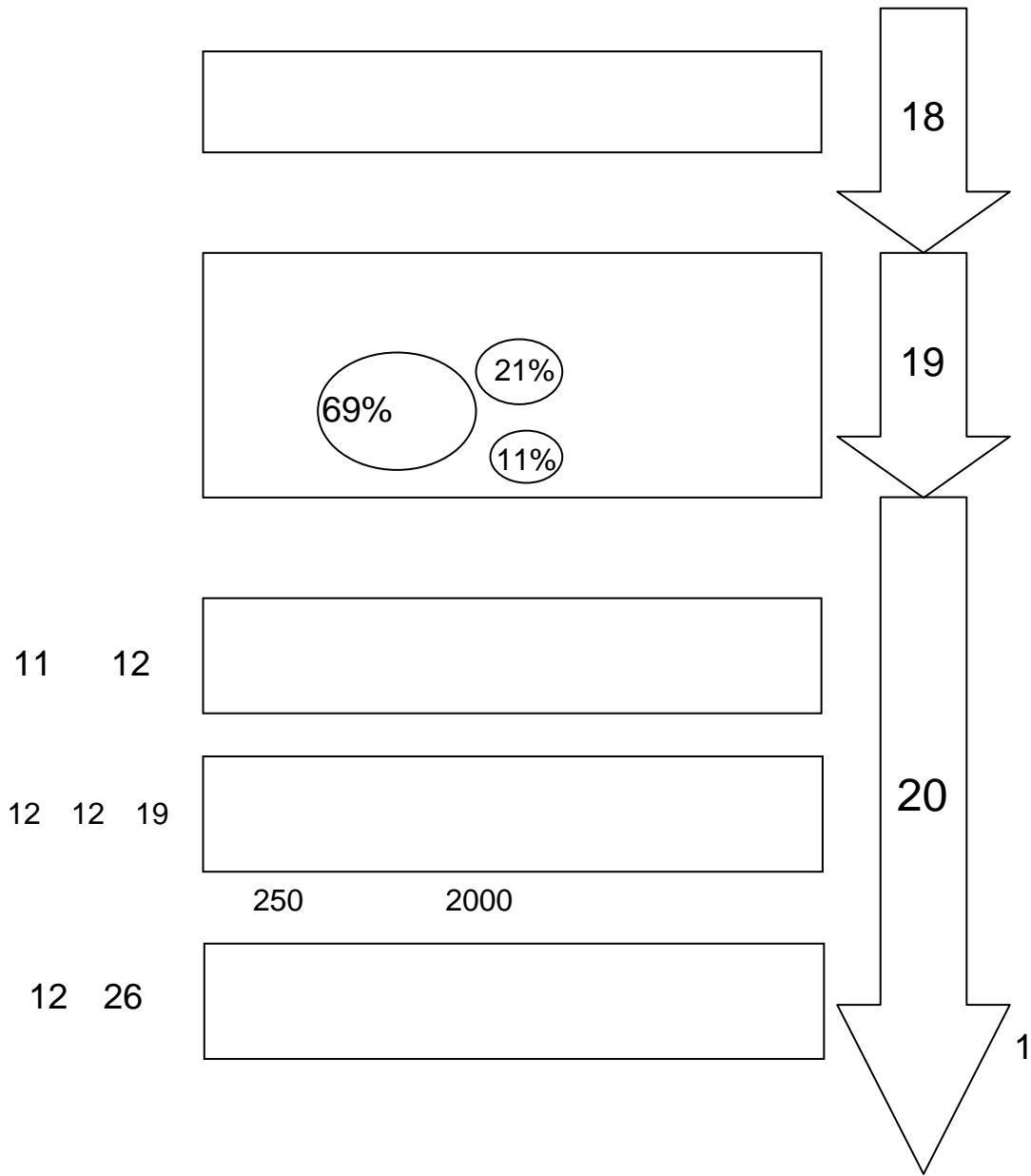

4

